

# 2024 PHS PHILADELPHIA FLOWER SHOW

## “United By Flowers” March 2 – March 10, 2024

### ARRANGEMENT CLASSES STAGING INFORMATION

#### CONTENTS

OPEN PLATFORMS (100-OP, 103-OP, 108-OP) .....	2
PEDESTALS .....	2
DRESS FORMS.....	3
SMALL NICHE (102-S, 105-S, 110-S).....	4
SMALL NICHE GUIDELINES .....	5
MEDIUM BACKED PEDESTALS (101-M, 104-M, 109-M).....	6
BACKED PLATFORMS (116-BP, 117-BP, 118-BP).....	7
GALLERIA (125-G, 126-G, 127-G) .....	8
LARGE BACKED PEDESTALS (129-L, 130-L, 131-L).....	9
HEAD FORMS, TABLETOP FRAMES.....	10
MINIATURE ARRANGEMENTS (119, 120, 121, 122, 123, 124).....	12
MINIATURE ARRANGEMENT GUIDELINES.....	13
MINIATURE BOX CONSTRUCTION TIPS .....	15
PHOTOGRAPHS OF NICHE LIGHTING .....	16

# OPEN PLATFORM

# 100-OP, 103-OP, 108-OP

Please be sure to read the *General Rules and Information* (page 10) and *Staging Information – Open Platforms* (page 11) in the *2024 Exhibitor's Guide*.

Staged on a platform 8' wide by 4' deep, 4" high. No part of the entry may extend beyond the edges of the platform.

Use of PHS pedestals is optional. Exhibitor may use **one or two** PHS pedestals—choice of three sizes (12" x 12" x 12", 12" x 12" x 24", 12" x 12" x 32"). If you opt to use PHS pedestals, please notify the Class Advisor about the number and size of the pedestals you are requesting. Quantities are limited, so they will be allocated on a first-come, first-served basis.

The staging will be painted "Olympus White" (Sherwin-Williams 6253).

Not to scale.

## PLATFORM

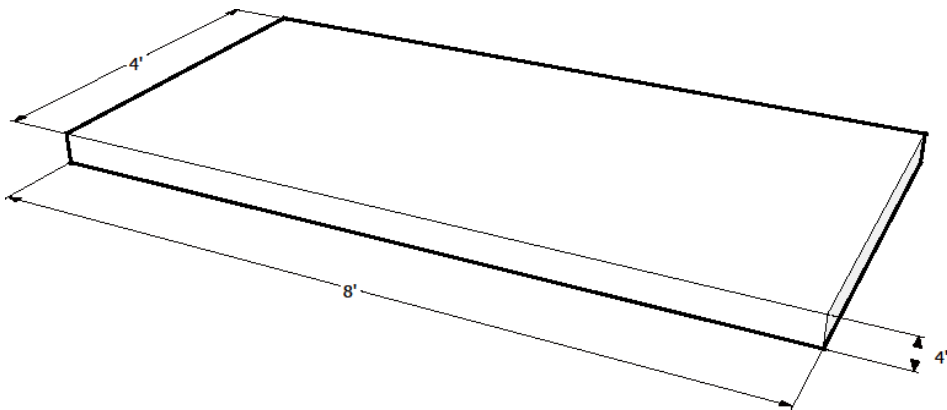

## PEDESTALS

12" x 12" x 12"

12" x 12" x 24"

12" x 12" x 32"

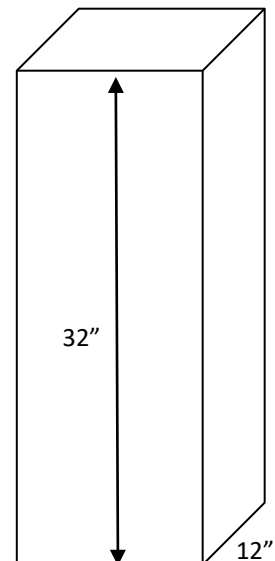
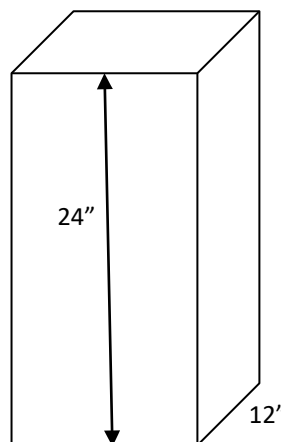
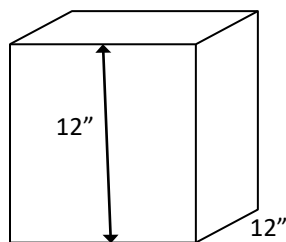

## DRESS FORMS (Class 108-OP)

Dress forms will be staged on a platform 8' wide by 4' deep by 4" high. No part of the entry may extend beyond the sides of the platform.

The dress form **may not** be elevated in any way and must stand on the platform itself. No rug, mat, or other materials may be placed beneath the dress form. No accessories of any kind may be placed on the platform.

You may not glue or otherwise permanently adhere materials to the dress forms. You may not paint or otherwise alter the dress forms.

A pre-made dress may be used as a starting point but should be significantly altered so that the finished entry is made **primarily** of plant material. Necklaces, belts, or other dress accessories are permitted if they are made **entirely** of plant material.

**Dress and accessory design ensemble:** Accessory may consist of dried material only. Accessory to be staged on a 12"x12"x 32" PHS pedestal positioned to the left of the dress form.

Not to scale.



# SMALL NICHE

102-S, 105-S, 110-S

Not to scale

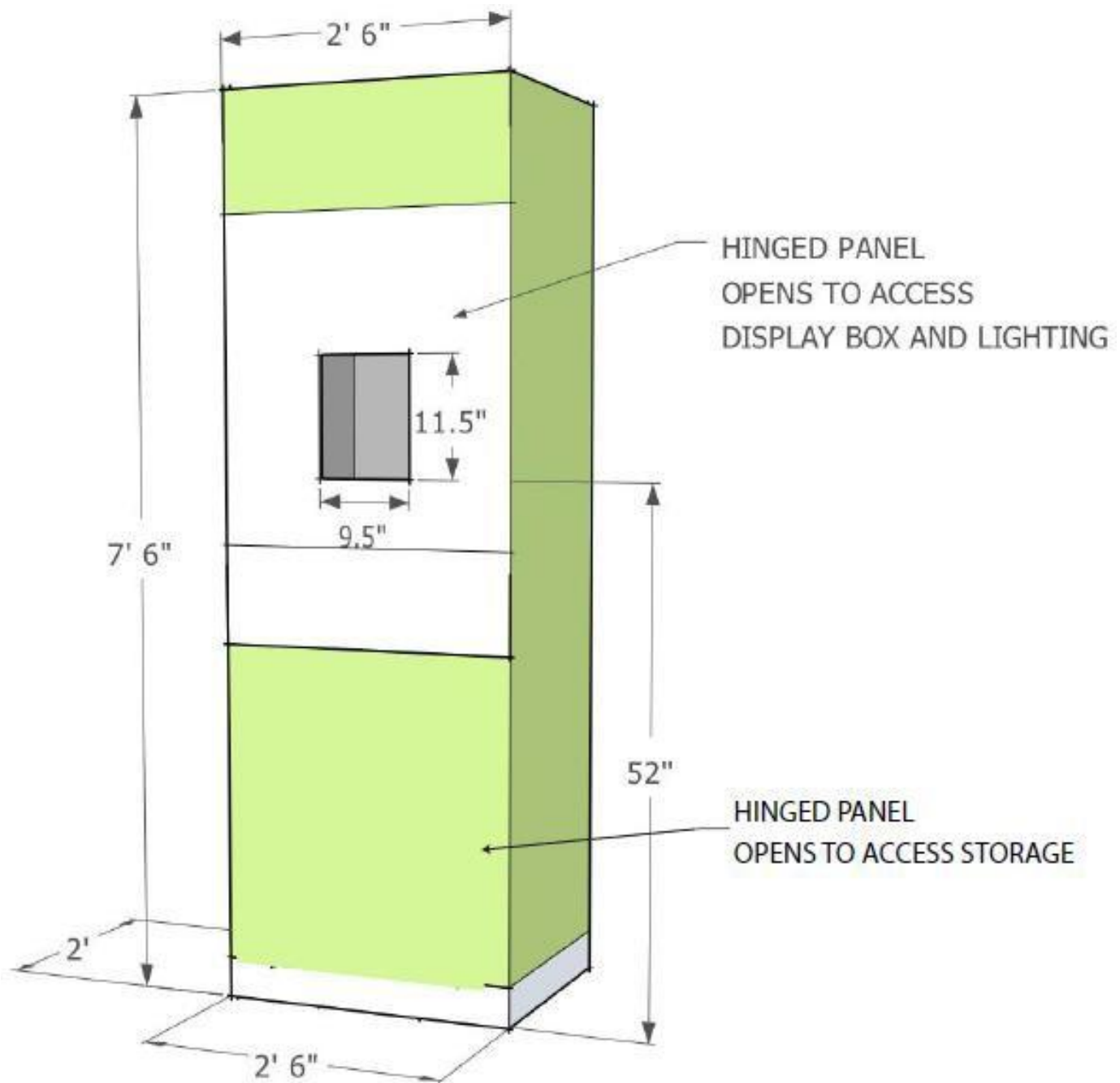

SMALL NICHE DISPLAY BOX  
10"w x 8"d x 28"h interior dimensions

## SMALL NICHE GUIDELINES

Please be sure to read the *General Rules and Information* (page 10) and the *Staging Information* (page 11) in the *Exhibitors Guide*.

### LINING A SMALL NICHE WITH MAT BOARD

These dimensions are approximate. Please test your linings in the niches that will be available at the PHS Artistic Workshops or in your own practice niche.

**Note: Niche boxes vary in precise measurements. During Show set-up, a technical team is available for making minor adjustments to mat boards.**

#### Interior Measurements

- Floor: 10" wide x 8" deep
- Back: 28" high x 10" wide
- Sides: 28" high x 8" deep

#### Mat Board Measurements

A straight or curved background may be used.

##### Mat Board – Straight Background

Cut back 25" high x 9 15/16" wide; 2 sides 25" high x 7 15/16" deep; floor 9 15/16" wide x 7 15/16" deep. If using foam core, cardboard, or fabric, be sure to allow for the thickness of the material.

##### Mat Board – Curved Background

Cut mat board 25" high and a width that accommodates the curved back you want to achieve. Gently curve the mat board into place to avoid any creases or bends. Floor 9 15/16" wide x 7 15/16" deep.

#### Lighting

Small niches are supplied with one light bulb. Lights are dimmable and swivel, although the light bar is fixed. Exhibitors may exchange the PHS bulb for a bulb color of their choice depending on the desired mood, but the bulb **MUST BE AN LED BULB NOT TO EXCEED 65 WATTS**. Replaced PHS bulbs must be stored safely in the niche storage area for the next exhibitor.

#### Niche Storage and Locks

There is a small area in the bottom of each niche for storing extra flowers and tools, as well as the PHS light bulbs, if you decide to change them out. Please remember that access to this storage during set-up and maintenance times requires the niche to be opened by an Advisor with the special magnetic key.

# MEDIUM BACKED PEDESTAL

# 101-M, 104-M, 109-M

Please be sure to read the *General Rules and Information* (page 10) and the *Staging Information* (page 11) in the *Exhibitors Guide*.

New for 2024. Design staged on a pedestal 12" wide x 11" deep x 44" high. The height of the back is 20" tall (with a total height of 64"). The staging will be painted "Olympus White" (Sherwin-Williams 6253). No backgrounds are permitted. Design may not exceed the width or height of back panel but may extend down the front of the base pedestal and may not touch the floor.

## MEDIUM BACKED PEDESTALS

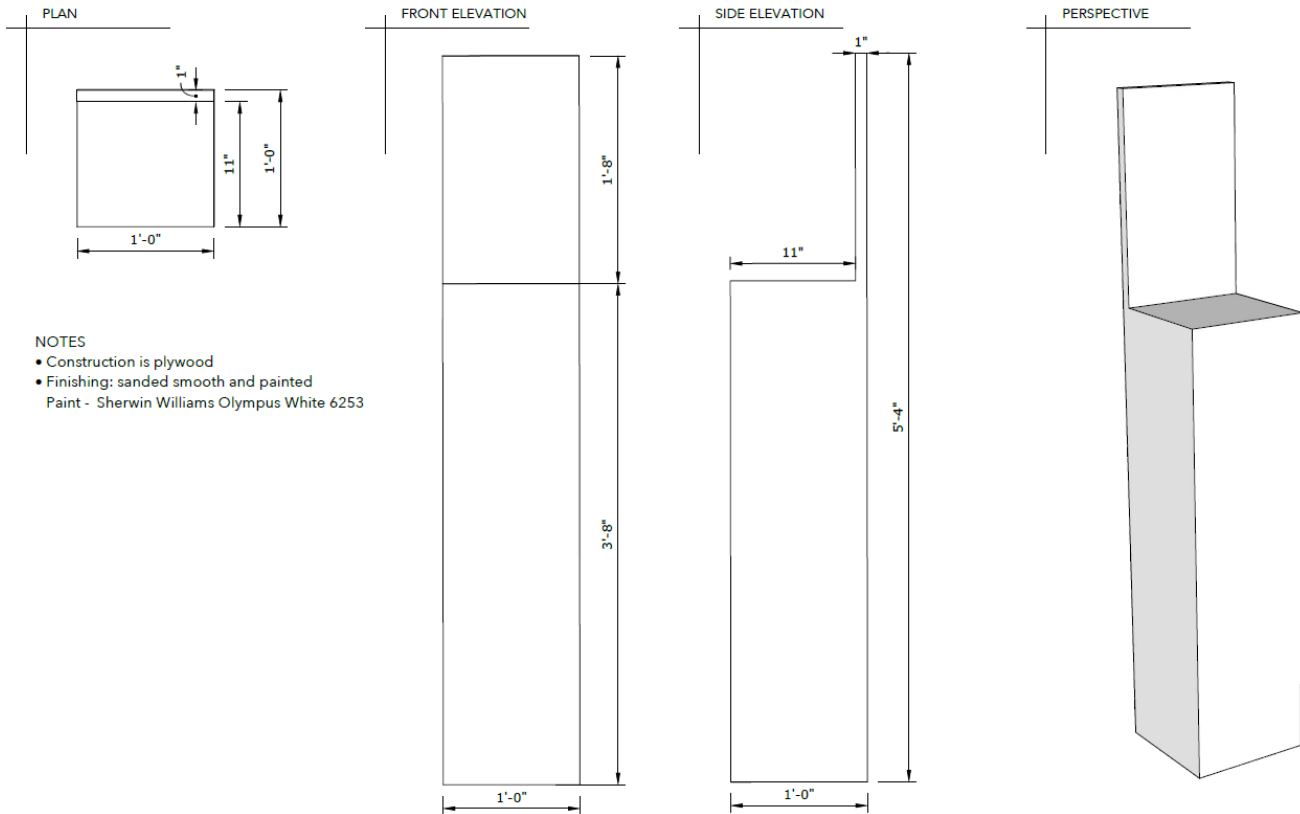

# BACKED PLATFORM

# 116-BP, 117-BP, 118-BP

Formerly Vertical Design. Please be sure to read the *General Rules and Information* (page 10) and the *Staging Information* (page 11) in the *Exhibitors Guide*.

A vertical/narrow design staged on a 30" x 30" square by 1" high platform, centered on a platform area that is 48" x 48" in front of a background panel measuring 48" wide x 92" high. The design must not exceed the perimeter of the 30" square platform. The staging will be painted "Olympus White" (Sherwin-Williams 6253). No backgrounds are permitted. Design not to exceed 7'.

## BACKED PLATFORMS

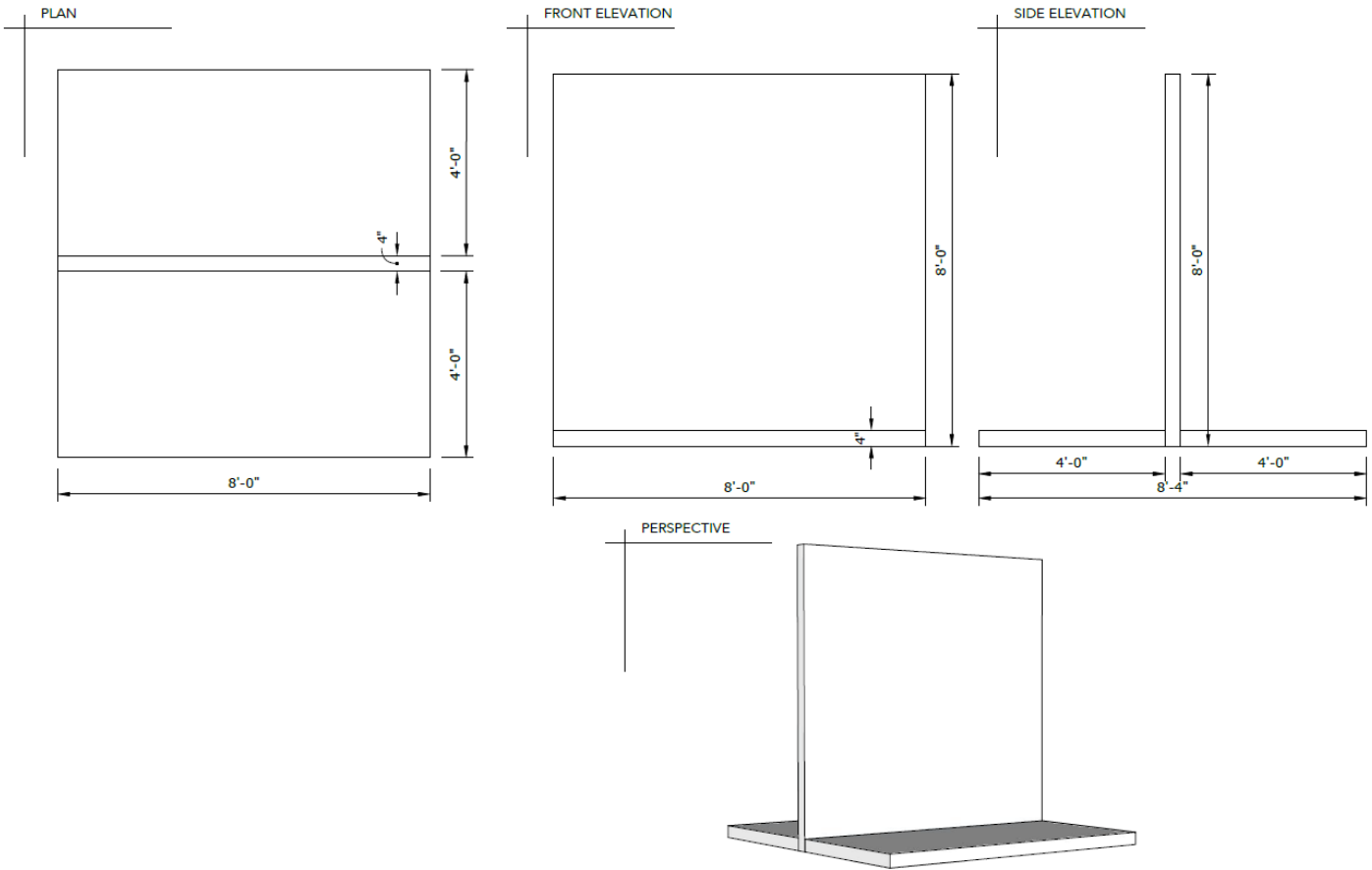

# GALLERIA

# 125-G, 126-G, 127-G

Please be sure to read the *General Rules and Information* (page 10) and the *Staging Information* (page 12) in the *Exhibitors Guide*.

Each exhibit space is a platform 8' wide, 8' deep, 4" high. The back wall of the area is 10' high. Optional pedestals—choice of two sizes (12" x 12" x 12", 12" x 12" x 24"). The staging will be painted "Olympus White" (Sherwin-Williams 6253).

Photographs of the objects to be interpreted in class 125-G, will be provided by PHS in January after your entry is confirmed. Please note: The object will be displayed on the left, with the arrangement to the right.

Not to scale.

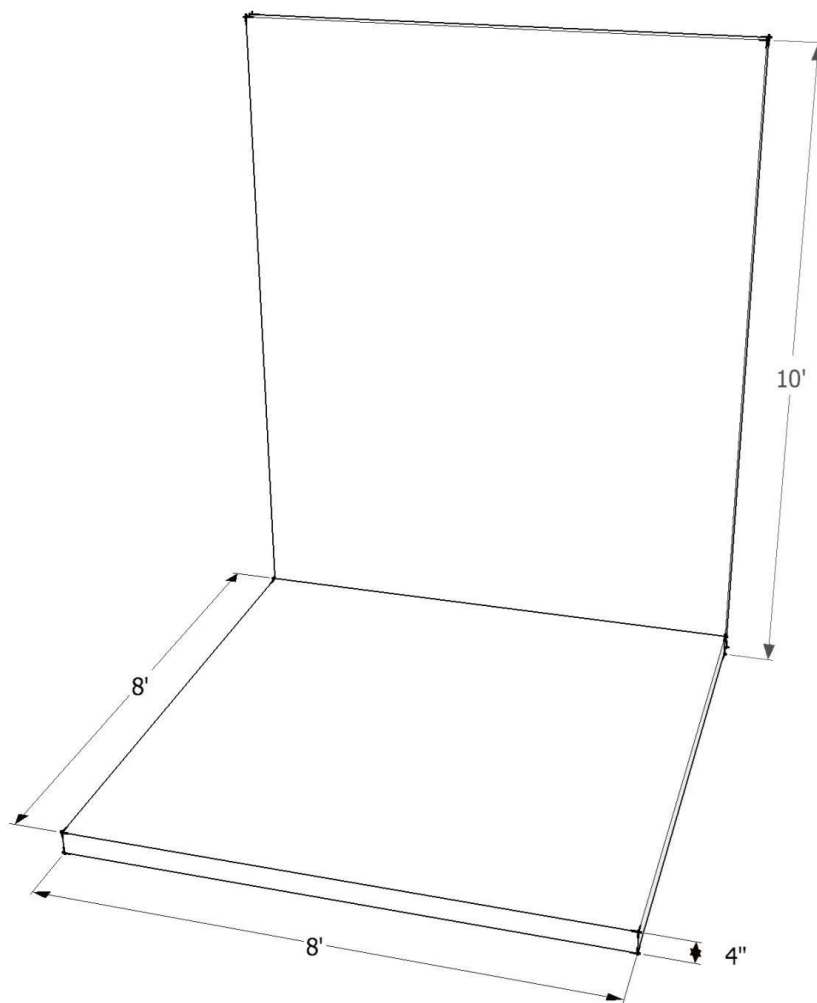



# LARGE BACKED PEDESTAL

129-L, 130-L, 131-L

Formerly Backed Pedestal. Please be sure to read the *General Rules and Information* (page 10) and the *Staging Information* (page 12) in the *Exhibitors Guide*.

Staged on a platform 8' wide, 4' deep, 4" high. Pedestals are 36" wide x 24" deep x 36" high; height of back is 36" (total height of unit on platform is 72").

**NEW:** Backgrounds are NOT permitted in any Backed Pedestal Class.

The staging will be painted "Olympus White" (Sherwin-Williams 6253).

Not to scale.

## BACKED PEDESTALS - NO PLATFORMS

---

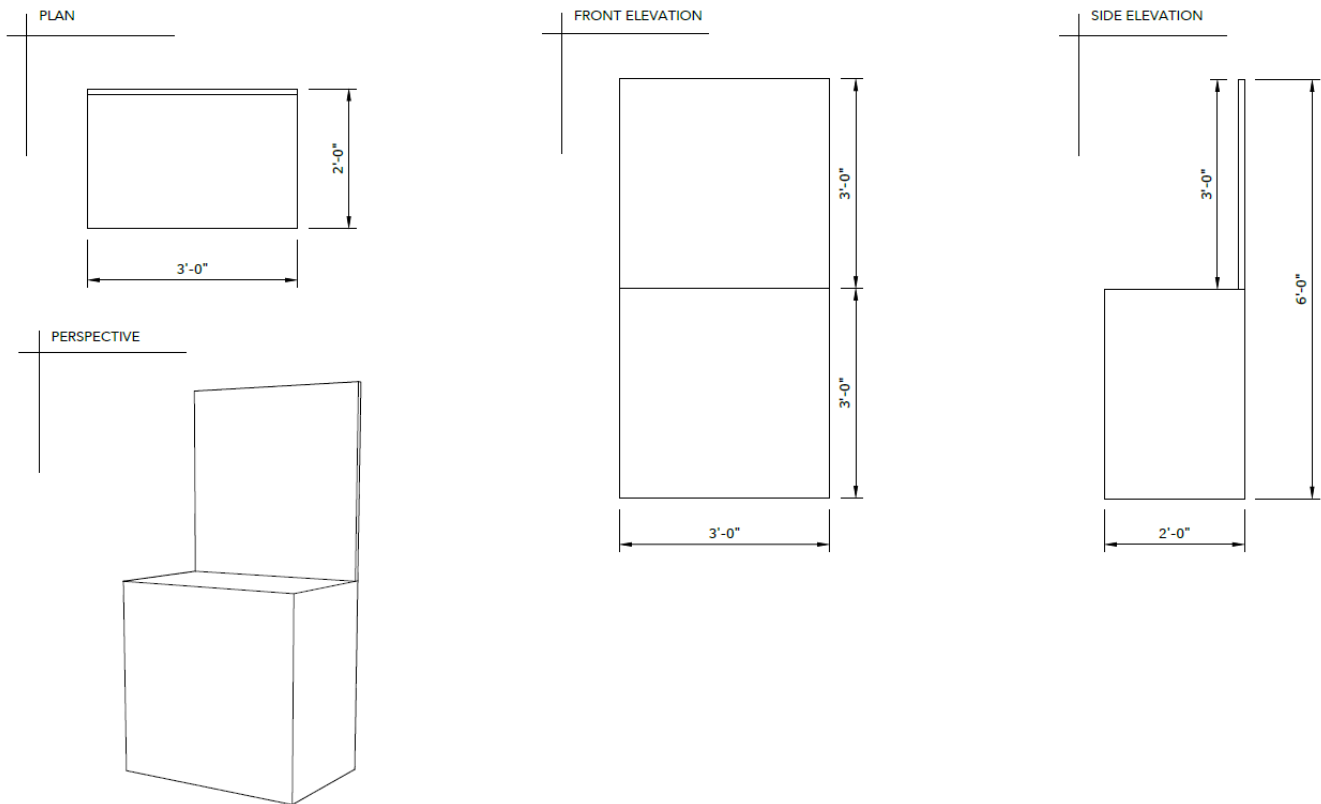

## ADDITIONAL CLASS INFORMATION

### Head Forms

- Head forms can be picked up in January with prior arrangement from PHS. If head forms must be shipped to the exhibitor, exhibitor must pay shipping charges. Please email Gabrielle Baugh at [gbaugh@pennhort.org](mailto:gbaugh@pennhort.org) with your pick-up plans
- You may not glue or otherwise permanently adhere materials to the head forms. You may not paint or otherwise alter the head forms, as the head forms are reused.
- Hats may be composed of a combination of dried and fresh plant material, but some fresh plant material **MUST** be used. How much fresh plant material to use is up to the exhibitor.
- Dried plant material may be painted. Fresh plant material may **NOT** be painted or colored in any way.
- Plant material intended to fulfill the class requirement for “fresh” must be fresh when the exhibit is entered. If fresh plant material is used without a water source, it is necessary to do one of two things:
  - 1) Plants must be tested to see if they will remain fresh for the time they are to be displayed and approved by one of the Passing Chairs at least one week prior to the Show.
  - 2) Plants **MUST** be replaced with fresh material each morning before the Show opens.
- The basic hat structure may be created entirely from “scratch,” or it may be created using an existing form. Whichever approach is taken, the requirement to conceal the mechanics with plant material applies, unless an aspect of the mechanics is used as a design element. If a ready-made hat is used, it must be entirely concealed with plant material.
- Accessories are **NOT** permitted (for example, a necklace, scarf, or earrings or any item that is not a part of the hat).
- Hat design should be in proportion to the head, not the size of the backed pedestal.
- **New:** Backgrounds are **NOT** permitted in this class. A mat, fabric, or any other materials may **NOT** be placed beneath the head form.

### Tabletop Frames

- Tabletop frames will be provided by PHS at the Show.
- Tabletop frames are painted “Samovar Silver” (Sherwin Williams 6233).
- You may not glue or otherwise permanently adhere materials to the frames. Temporary hooks, wires, and other mechanics may be used if they do not damage or discolor the frame in any way.
- You may not paint or otherwise alter the frames, as the frames are reused.
- You **MAY NOT** remove any of the eye hooks. The eye hooks have been designed to be inconspicuous, so any unused eye hooks will not detract from the overall appearance of your exhibit.
- The design may include dry plant material, but fresh plant material **MUST** predominate.
- The frame must remain placed in the middle of the Backed Pedestal when viewing it from the front.
- The design should be in proportion to the overall size of the backed pedestal. The design may extend beyond the sides, top, and front of the tabletop frame, but **MAY NOT** extend beyond the sides, top, or front of the Backed Pedestal.
- The designer may incorporate a variety of components into their design (such as material, fabric, etc.), if the framed area is **NOT** totally covered (i.e., with a backdrop) and some portion of the Backed Pedestal remains visible through the completed design. Fabric must be treated with fire retardant (see page 7 of the *Exhibitor’s Guide*).
- Backgrounds are **NOT** permitted in any Backed Pedestal Class. A mat, fabric, or any other materials may **NOT** be placed beneath the frame.

Not to scale.

**BACKED PEDESTAL FRAMES**

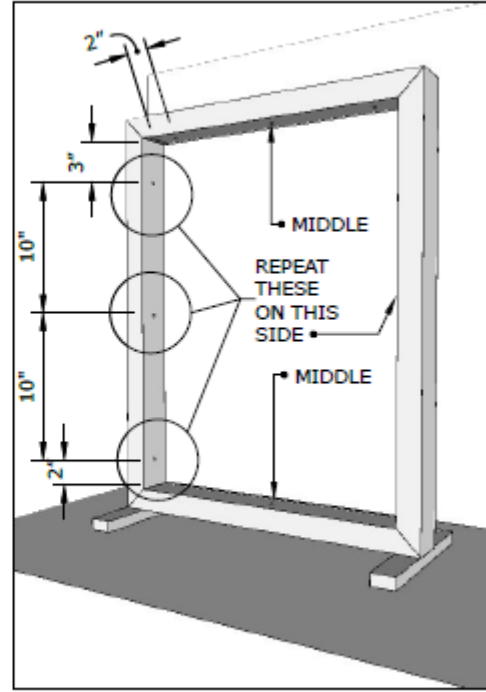
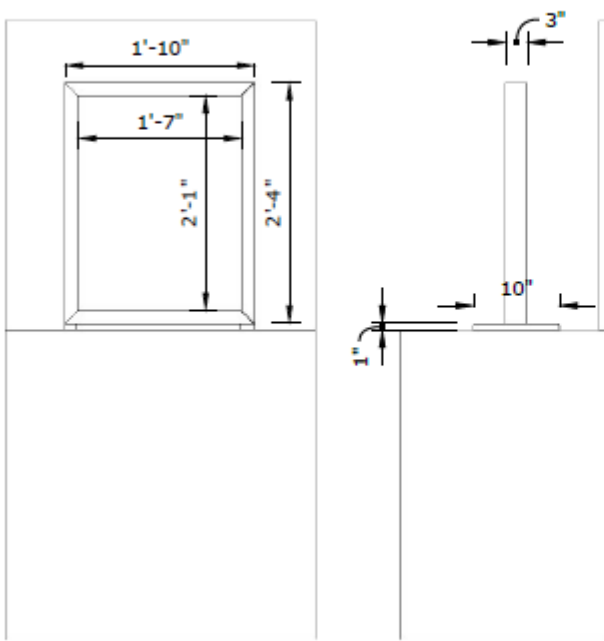

Eye hook locations on frames - total of 10

# MINIATURE ARRANGEMENTS

119, 120, 121, 122, 123, 124

Not to scale.

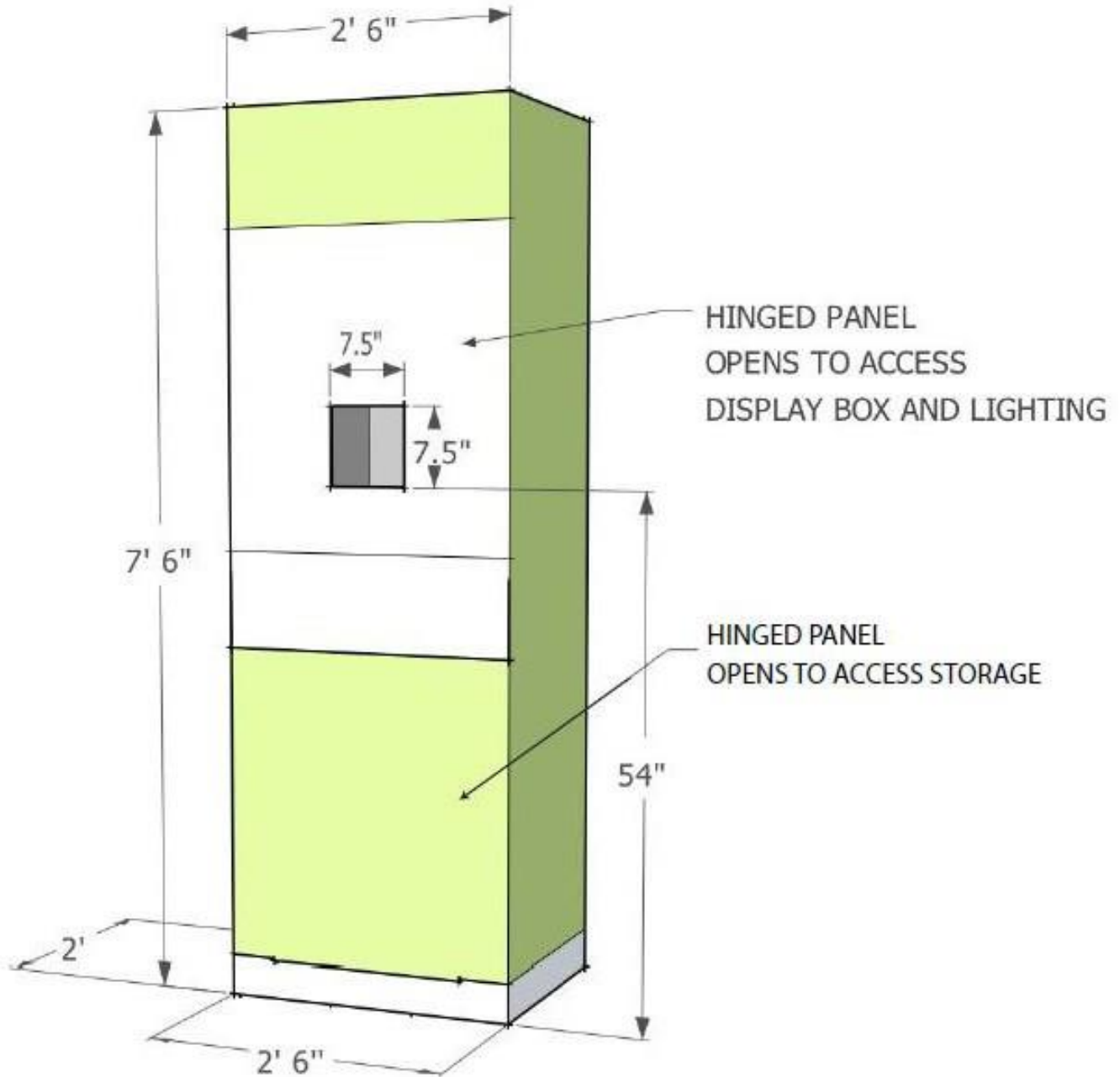

MINI NICHE DISPLAY BOX  
8"w x 8"d x 16"h interior display box

# MINIATURE ARRANGEMENT GUIDELINES

Please be sure to read the *General Rules and Information* (page 10) and *Staging Information – Miniature Arrangements* (page 12) in the *Exhibitor's Guide*.

## Interior Measurements

- Bottom: 8" wide x 8" deep
- Back: 16" high x 8" wide
- Sides: 16" high x 8" deep.

**Mat board** is required, no poster board or other material is allowed for lining minis. No fabric or other material may be attached to the mat board.

## Mat Board Measurements

- Cut one back and two sides 7-15/16" wide x 12" high (minimum) to 15-1/2" high (maximum)
- Cut bottom 7-15/16" wide x 7-15/16" deep.

A curved mat board back may be used, if interior dimensions remain 8" wide by 8" deep.

Use of a frame, to mask the raw edges of the niche and frame your design, is permitted. PHS will have available 1" square black mat frames to borrow. Alternatively, you may provide a frame of your own shape and color. Total covering of the framed opening is not permitted. Use of a frame is optional.

**Hint:** Make sure that all pieces are headed in the same direction so that the color and shading match. If you are cutting your own mats (see below), cut them all in the same direction. Mark an arrow indicating such on the back of each piece. Also indicate left side, right side, and back. Mat board should be taped in place using masking tape or other tape that will not permanently mar the PHS niche box. All tape and residue must be removed when entry is removed.

**Hint:** Bring extra scraps of mat board to help ensure your mat fits tightly in niche box without gaps at back corners. Use of a frame to mask the raw edges of the niche and frame your design is permitted. PHS will have available 1" square black mat frames to borrow. Alternatively, you may provide a frame of your own shape and color. The opening of the display box measures 7.5" x 7.5", and the frame, if used, will be placed on the inside of the door. Total covering of the framed opening is not permitted. Use of a frame is optional.

## To Cut Your Own Frame

Exterior dimension should be at least 9" x 9" but 10" x 10" is a safer measurement for extra room. Interior is approximately 6" x 6", so that the frame is actually ~2" wide, with extra outside space. 1-2 inches rest behind the niche opening, one inch or more show to the outside. You may also choose a different shape opening that enhances your overall design. Choose a mat with full thickness color, paint the exposed edge with an exact match paint color, or reverse miter cut your mat so that the raw white edge does not show.

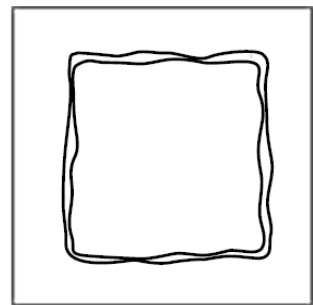
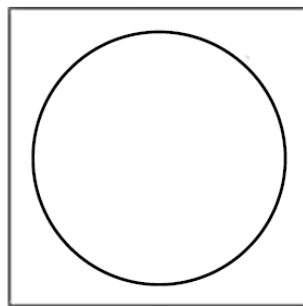
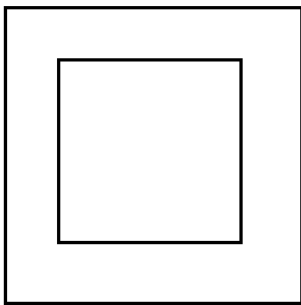

**Hint:** If you bring your own black frame, write your name on the back of it so it won't be confused with the PHS frames, which are returned to PHS.

## **Lighting**

Miniature arrangements come with one light fixture, and bulb are provided. The light is fixed in place so it cannot be moved, but it can be dimmed. You **MUST** use the PHS light bulb provided.

## **Other Information**

Fresh plant material **CANNOT** be used in a miniature arrangement.

Arrangements cannot exceed 5" in height, width, or depth. To ensure your design does not exceed this requirement, make a 5" square out of cardboard and hold it up to your arrangement on all sides. If nothing shows in any direction, you are good to go.

## **Niche Boxes**

PHS provides a niche box for each exhibitor on the Show floor. Alternatively, exhibitors may build their own niche box so it can be drilled into it and pre-assembled. It is critical that constructed niche boxes are the exact size of those provided by PHS. See construction information that follows.

## **Niche Storage and Locks**

There is a small area in the bottom of each niche for storing extra flowers and tools, as well as the PHS light bulbs, if you decide to change them out. Please remember that access to this storage during set-up and maintenance times requires the niche to be opened by an Advisor with the special magnetic key.

## **Dowels for suspending arrangement:**

How to create sliding dowels to hang arrangement.

Materials:

2 dowels ¼" square, usually 4' long

Cut 2 or 3 pieces 10-11" long

Cut 4-6 pieces 4" long

Create 2 "H"s, each at the ends of the long pieces, which can slide along the top of the niche box to hang your piece wherever you choose, or you can create a hanger with 2 or 3 dowels. Glue pieces together. Make sure to test on niche box before affixing permanently to be sure it will fit over the top sides of the box. Whether using single, double, or triple dowel frames, it is best to secure your arrangement in three places to prevent swinging. Use either clear nylon thread or an exact match to your mat board, as fishing line can "grow" under the lights.

## **Holding design through the center:**

**HOW TO ATTACH FROM BEHIND TO APPEAR AS IF FLOATING:**

\*This can only be done on your own niche. Do not attempt to drill holes in niche supplied by PHS.

Position arrangement in box at height and location desired. Mark the back of the box and drill through box using a drill bit that is sized to match the skewer of choice. Be sure to paint the skewer to match the background color, and then push the end of the skewer into your arrangement, the arrangement won't move at all.

If using a PHS box or if you choose not to drill through your own box, start by cutting a hole into the background at desired height. To stabilize the skewer, cut a small piece of foamcore or Styrofoam and place it in position at the back side of the background so that the skewer can stick into it. Tape with duct tape or masking tape to firmly hold the skewer with design attached! Overnight trial is definitely encouraged! Doing that means that the back comes forward into the niche just a bit. (If it's your own box, then you can stick the foamcore onto the back of the box.)

# MINIATURE ARRANGEMENT BOX CONSTRUCTION TIPS

## Materials

- 1/2" plywood sheet measures 2' x 4'
- Wood glue

## Need to Cut

- One back: 8" x 15 1/2"
- Two sides: each: 8 1/2" x 15 1/2"
- One floor: 8" x 8"

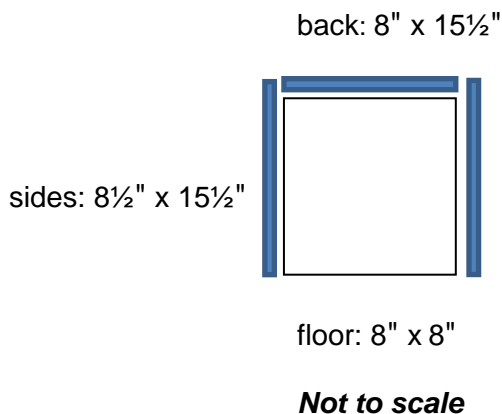

To finish: Position back and sides around the floor. Glue back and sides together, gluing sides alongside the back, so that the floor space is 8" x 8".

Put glue on 3 sides of the floor and slide it into the back and sides pieces. Write your name on the back of the box.

Video about how to create a mini box: <https://youtu.be/v2Pg6fzQsg4>

## Assembled (not to scale)

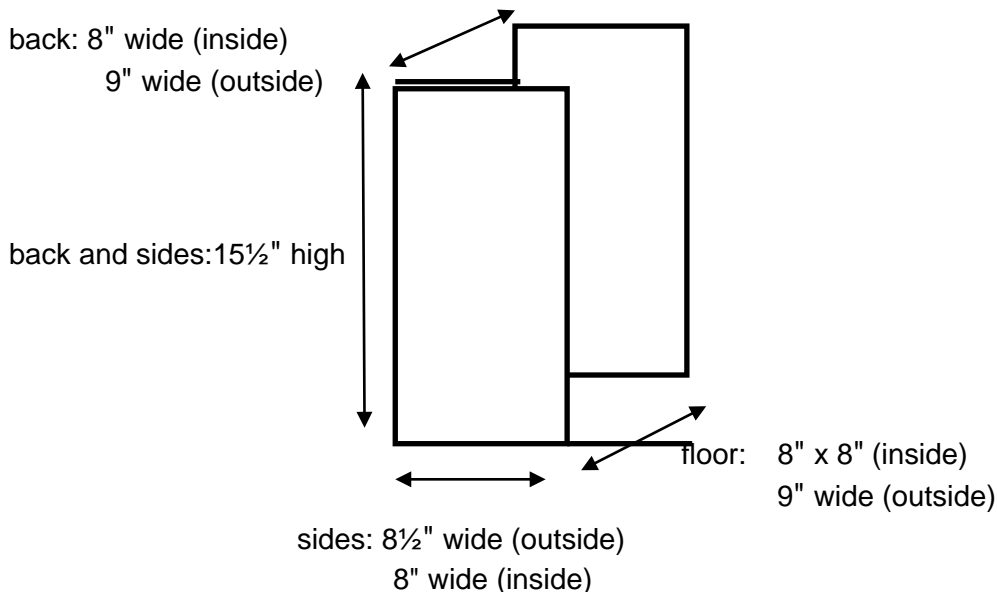

## PHOTOGRAPHS OF NICHE BOX LIGHTING



**SMALL**

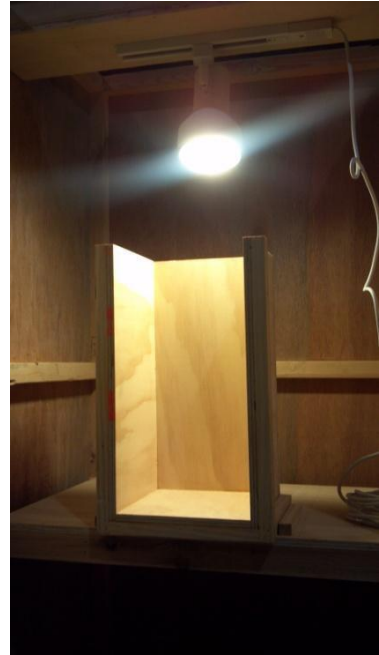

**MINI**